

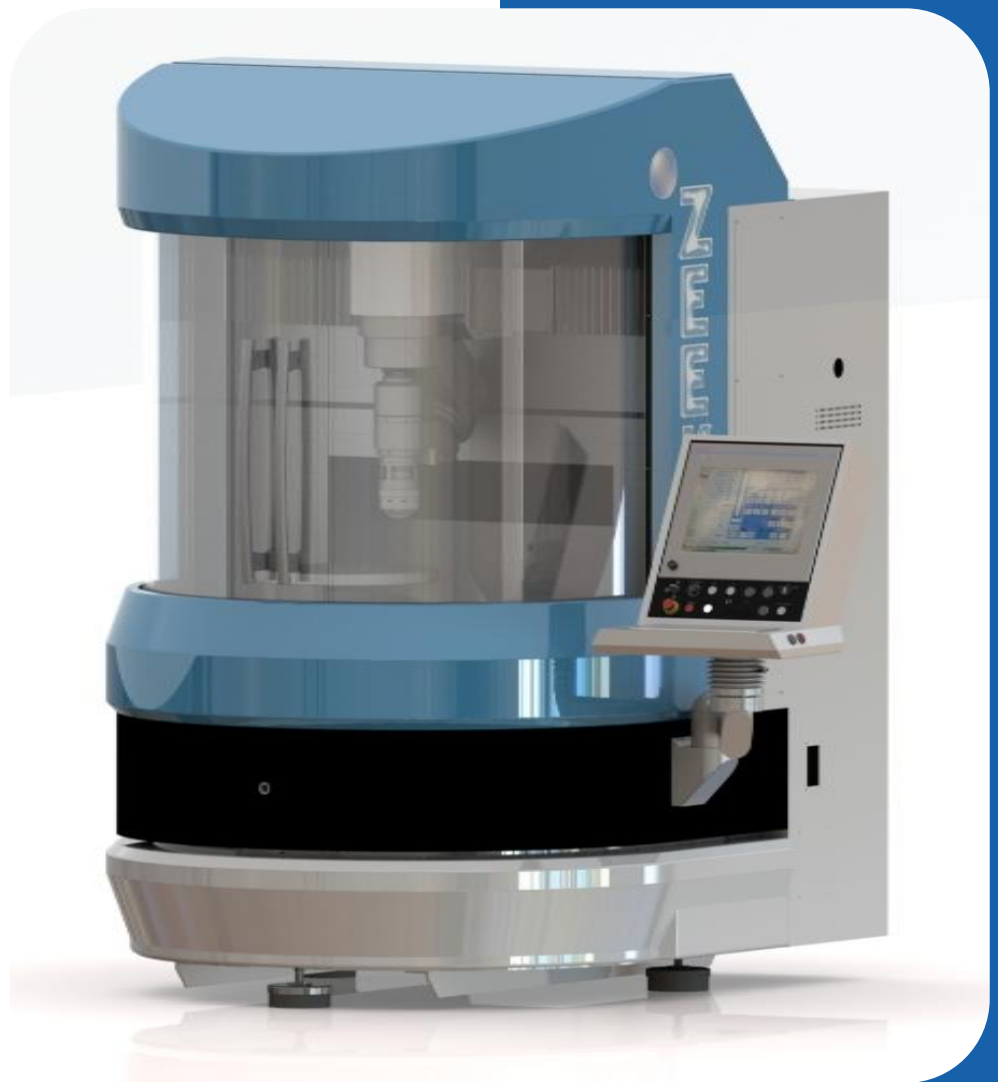

IRP400 7Axis Fanuc - XY Linear

Product Specification - Version 2, Release 3



Zeeko

Rev. 230106

Contents

1	Machine Description	2
2	Arrangement of the Axes	3
3	Polymer Granite Machine Base and Bridge.....	4
4	Linear Axes	5
	4.1 X- and Y-Axes	5
	4.2 Z-Axis	5
5	Rotary Axes & Spindles.....	6
6	Machine Enclosures	8
7	Control System.....	9
8	Guards, Covers & Safety Features.....	10
9	Peristaltic Pump System (Option).....	11
10	ZeekoJet Polishing (Option).....	12
11	Summary Specification	13
	11.1 General	13
	11.2 Linear Axes.....	13
	11.3 Rotary Axes	14
12	Utilities Specification	15
	12.1 Power Supply	15
	12.2 Compressed Air	15
	12.3 Environmental Specification	15
	12.4 Temperature and Humidity.....	15
	12.5 Cleanliness.....	16
	12.6 Room Vibration Requirements	16
	Contact	16

1 Machine Description

The IRP400 is a 7 axis CNC optical polishing/form generating machine capable of producing ultra-precise surfaces on a wide range of materials and surface forms. The machine axes can be used for traditional spiral, raster, and free-form polishing.

- ❖ Mass = 2600 Kg
- ❖ Dimensions = 2100 x 1850 x 2275 (W x D x H mm)

The machine frame is a welded steel structure incorporating the following features:

- ❖ 3 point floor mounting
- ❖ Integrated electrical and pneumatics enclosures
- ❖ 3-point mounting for polymer-granite base
- ❖ Peristaltic System attached (optional)

2 Arrangement of the Axes

The arrangement and definition of the 7 CNC axes is as follows:

- ❖ X is a linear axis which mounts horizontally to the polymer-granite bridge. The X axis carriage is a precision machined steel structure.
- ❖ Y is a linear axis comprising a precision machined steel structure, mounted on the polymer-granite base and aligned perpendicular to the X axis.
- ❖ Z is a linear axis, precision machined steel structure, mounted vertically on the X axis and is aligned perpendicular to both the X and Y axes.
- ❖ C is a rotational axis that holds the work piece. It is mounted on the Y-Axis.
- ❖ A, B and H are rotational axes configured such that the polishing head (H axis) rotates through a point in space call the Virtual Pivot (VP). This three axis assembly mounts onto the Z-Axis.

3 Polymer Granite Machine Base and Bridge

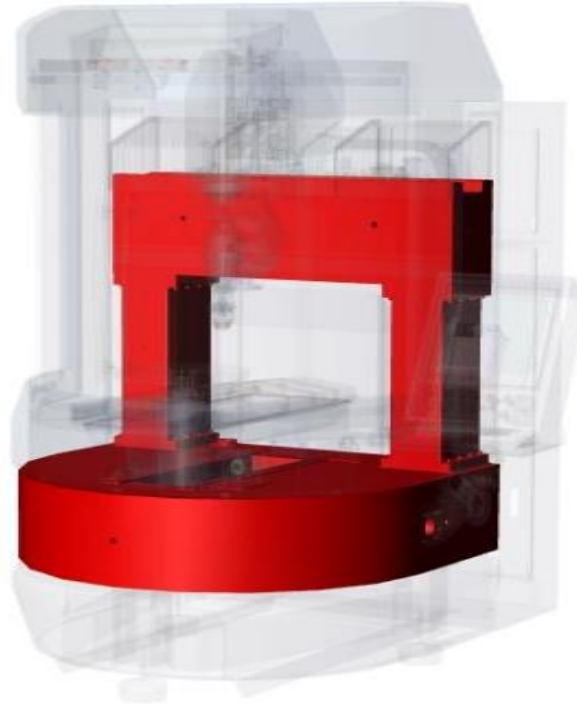

Figure 1: Polymer Granite Base & Welded Steel Frame

The machine base and bridge are precision cast and machined polymer-granite composite structures that provide excellent thermal stability and vibration damping characteristics. This key machine element incorporates the following features:

- ❖ Moulded-in stainless steel inserts for mounting and alignment of the X and Y axes and for machine handling and transportation.
- ❖ Threaded stainless steel inserts for mounting the polishing enclosure.
- ❖ Moulded-in feeds for electrical supply and control cables, compressed air, and slurry supply and return.

4 Linear Axes

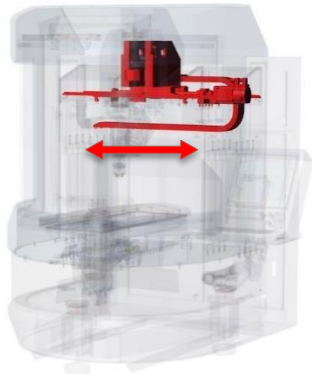

Figure 2: X Axis



Figure 3: Y Axis

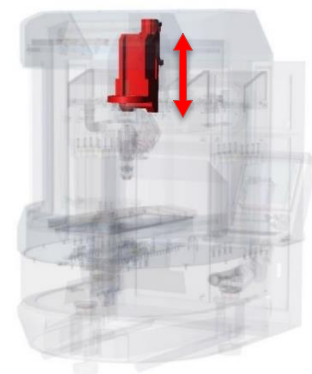

Figure 4: Z Axis

Each axis is mounted on a pair of precision linear motion rails and driven via an AC servo. Glass scale linear encoders are used on each linear axis (Z optional) for positional accuracy.

4.1 X- and Y-Axes

The X- and Y-axes are driven by Fanuc linear motors and do not require ballscrews for drive. Positional feedback is by precision glass scale encoders.

- ❖ Slide type: THK or INA linear motion rails
- ❖ Travel (X Axis): ± 275 mm
- ❖ Travel (Y Axis) ± 250 mm
- ❖ Drive system: Fanuc linear AC servomotor
- ❖ Positioning feed-back: Precision glass scale encoder
- ❖ Max velocity: 3000 mm/min

4.2 Z-Axis

The Z-axis drive is provided by a ballscrew drive using a Fanuc AC servomotor coupled to a linear glass scale encoder.

- ❖ Slide Type: THK or INA linear motion rails
- ❖ Travel: 250 mm
- ❖ Drive: Fanuc AC servomotor with pulsecoder
- ❖ Positioning feed-back: Precision glass scale encoder
- ❖ Max velocity: 3000 mm/min

5 Rotary Axes & Spindles

The A,B & H axes provide the primary tool motions and are often referred to as the Virtual Pivot (VP). The VP is mounted directly to the polymer-granite base.



Figure 5: A Axis

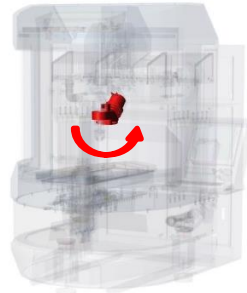

Figure 6: B Axis

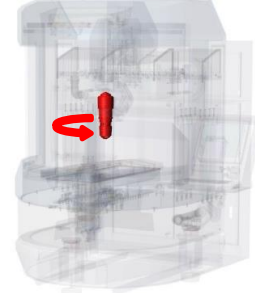

Figure 7: H Axis

The A-axis is mounted to the Z-Axis via an AC servo drive Harmonic Drive unit with enhanced radial stiffness. Referencing of the position is via a non-contact referencing element. Referencing is only required following power up of the machine.

- ❖ Rotational Range: $\pm 270^\circ$
- ❖ Max Rotational Velocity: 25 rpm

The B axis is mounted to the A axis via AC servo driven Harmonic Drive unit. Referencing of the position is via a non-contact referencing element. Referencing is only required following power up of the machine.

- ❖ Rotational Range: $\pm 180^\circ$
- ❖ Max Rotational Velocity: 25 rpm

The H axis forms the tool holding spindle and is mounted to the A & B axes and completes the virtual pivot assembly. Drive is provided via a DC frameless motor with position feedback from a rotary encoder. The spindle is cooled by an external chiller system. Tooling mounts via a $\varnothing 25\text{mm}$ hydraulic chuck. The H axis also integrates a load cell arrangement to facilitate part probing essential for process stability and part/machine referencing.

- ❖ Speed Range: 10 to 2500
- ❖ Polishing Head radii: Solid or Inflatable R20, R40, Inflatable R80, (Solid R2, R5, R10 optional¹)

¹ Fixturing may be required to allow the small tools to reach the surface of the component



Figure 8: C Axis/Spindle

The C Axis forms the work piece mounting spindle and is mounted to the Y-Axis. The axis consists of rolling element bearings driven by a Brushless DC servo motor, with positional feedback provided by a precision absolute encoder. The spindle is cooled by an external chiller system.

The Spindle is supplied with a Ø450mm turntable and Ø40mm hydraulic chuck for work piece mounting.

- ❖ Speed Range: 0 to 400 rpm
- ❖ Speed Range (optional) 0 to 1000 rpm (optional upgrade and with chuck only fitted)
- ❖ Max Load Capacity: 50kg
- ❖ Vacuum (Optional): -0.8bar maximum

6 Machine Enclosures

The Machine enclosures are provided as follows:

- ❖ Uncoated stainless steel polishing enclosure (internal surfaces)
- ❖ Slurry return drain passing through the granite base.
- ❖ Slide protection for the X, Y, and Z axes.
- ❖ Isolated machine electrical and pneumatic systems.
- ❖ Maintenance access to X, Y, and Z axes.

7 Control System



Figure 9: Control Console

Zeeko Fanuc (30i-B) System

- ❖ Industrialised PC with 15" Touch Colour LCD Screen with Softkeys
- ❖ Multi-axes interpolation (export controlled) with cubic, polynomial, and B-spline (NURBS) capability
- ❖ Designation of control paths: 1 path
- ❖ Least Command Increment: 1µm
- ❖ Processor: Panel i - Windows embedded OS (Zeeko reserves the right to ship Win XP, 7 or 10).
- ❖ Data Server option for up to 4GB NC programs

8 Guards, Covers & Safety Features

The equipment specified herein shall conform to requirements of EC and international safety regulations as required by current legislation.

Cover and guards will be provided to protect the operator from:

- ❖ Moving machine parts
- ❖ Slurry and spray

Covers will also protect machine elements from:

- ❖ Slurry and fluids
- ❖ Airborne dust and debris

Electrical interlocks will prevent opening of:

- ❖ The polishing enclosure door when the machine is in cycle.
- ❖ Electrical cabinet when the machine is energised

An emergency stop button readily accessible to the machine operator

9 Peristaltic Pump System (Option)

The Zeeko mounted peristaltic slurry delivery system can be used to supply polishing slurry in either a closed loop or open loop, total loss system.

High flow rate Pump specification (recirculating or total loss):

- ❖ Flow rate: Min flow rate: 75ml/min
 Max flow rate: 280ml/min
- ❖ Reservoir capacity: 1 litre
- ❖ Tube Type: Ø4.8mm Masterflex PharMed BPT
 Long life, high acid/alkali resistance
- ❖ Agitation method: Magnetic stirrer.

Low flow rate pump specification (recirculating or total loss):

- ❖ Flow rate: Min flow rate: 8ml/min
 Max flow rate: 30ml/min
- ❖ Reservoir capacity: 1 litre
- ❖ Tube Type: Ø1.6mm Masterflex PharMed BPT
 Long life, high acid/alkali resistance

Agitation method: Magnetic stirrer.

10 ZeekoJet Polishing (Option)

H-axis is a 'combo head' capable of Classic polishing and additionally Fluid Jet Polishing (FJP). FJP specification is as follows:

- ❖ Bonnet and hydraulic chuck are removed and optional FJP adaptor is assembled. Adaptor has removable probe for probing routines.
- ❖ Nozzle bore range available: 0.25, 0.5, 1.0, 1.5mm
- ❖ Maximum rated pressure is 20bar.

11 Summary Specification

11.1 General

General	Description
System Configuration	7 Axis CNC Optical Polishing Machine constructed on Polymer Granite Machine Base and Bridge, capable of producing ultra-precise surfaces on a variety of optical materials and surface forms.
Work piece Capacity (1)	Nominal polishing envelope of 550x500x250mm
Base Structure	Polymer Granite
Control System	Fanuc
Dimensions (No Accessories) WxDxH	2100mm x 1850mm x 2275mm
Suggested Install Dimensions	3100mm x 3850mm x 2400mm
Weight	2600Kg
Floor Load Requirements	Minimum loading 100,000Kg/m ² Floor must be even to <3mm/m ²
Environmental Requirements Min/Max Operating Temp. Max Operating Humidity Min/Max Storage Temp. Max Storage Humidity	15°C - 35°C (<2°C/hour Temperature Gradient) 75% RH Non Condensing -15°C - 50°C 80% RH Non Condensing
Power Supply Requirements	3Phase+E, 200 VAC 50/60Hz 8 kW (customer must supply a transformer or power supply to meet this specification)
Services Requirements	Clean dry air at 185L/min with minimum pressure of 6bar (215L/min with linear encoders)
Noise Level	<50dB(A) Continuous
Safety	In accordance with EC Directives 2006/42/EC, 2004/108/EC (EMC) and 2006/95/CE (Low Voltage)

11.2 Linear Axes

Description	X	Y	Z
Slide Type	THK or INA Linear Motion Rails	THK or INA Linear Motion Rails	THK or INA Linear Motion Rails
Drive Type	Fanuc AC linear servo motor	Fanuc AC linear servo motor	AC Servo driven Ø35-6 precision grade-C5 ballscrew
Feedback Type	Glass scale linear encoder	Glass scale linear encoder	Motor mounted position encoder or optional Glass scale linear encoder
Travel	±275mm	±250mm	+5mm , -245mm Max VP-Turntable Distance=(296)mm Min VP-Chuck Face Distance=(45)mm
Max Velocity	3000mm/min	3000mm/min	3000mm/min
Max Acceleration	250mm/sec ²	250mm/sec ²	250mm/sec ²
Positioning Accuracy	<10µm over full travel	<10µm over full travel	<10µm over full travel
Bi-direction Repeatability	<5µm	<5µm	<5µm
Straightness: Horizontal: Vertical:	<10µm over full travel <5µm over 100mm	<10µm over full travel <5µm over 100mm	<10µm over full travel <5µm over 100mm
Squareness	<50µ/m	<50µ/m	<50µ/m
Circularity	<50µm	<50µm	<50µm

11.3 Rotary Axes

Rotary Axes	A	B	H (Tool)	C (Workpiece)
Mounting	Epoxy-Granite Base	A Axis Arm	Virtual Pivot Assembly	Z Axis Carriage
Spindle/Axis	Axis	Axis	Spindle	Spindle & Axis
Cooled	Not Req'd	Not Req'd	Yes	Yes
Integral Services	N/A	N/A	Air (STD)/FJP (Optional)	Vacuum (Optional)
Probing	N/A	N/A	125N Load Cell	N/A
Drive	Harmonic Drive Direct Drive	Harmonic Drive Direct Drive	Emoteq DC Frameless Direct Drive	DC Frameless Direct Drive
Feedback Type	Motor Encoder	Motor Encoder	Rotary Encoder, 5000lines/min	Absolute Encoder
Speed Range	0-25rpm	0-25rpm	0-2500rpm	0-400 RPM (table) 0-1000 RPM (chuck only)
Load Capacity	N/A	N/A	N/A	50Kg
Maximum Inertial Load ²				2.0Kg*m ² @239rad/s ²
Positional Repeatability @ Motor	±1arcmin	±1arcmin	-	±1arcmin
Working Range	±270°	±180°	Continuous- bi directional	Continuous- bi directional
Radial Run-Out	Rotation of VP Setting ball mounted in H Axis Chuck and rotated about the Virtual Pivot < 40µm			<5µm
Axial Run-out				<10µm

² Maximum Inertial load in standard configuration. Variations may be possible with servo retuning – contact Zeeko for advice.

12 Utilities Specification

12.1 Power Supply

The machine is designed for operation on 3-phase, 4 wire systems (i.e. 3 phases + Earth). The machine can accept the following mains voltage:

3-phase + Earth, 380 – 430 V AC, 50 or 60 Hz. 10 kW capacity.

If the local electrical power supply standard does not meet this specification, then an electrical power transformer must be used between the local electrical supply and the IRP machine to the following output-side recommendation:

400 V AC 3-phase + Earth, 50 or 60Hz with 10 kW capacity.

The 10 kW rating is nominal and may be affected by customized design requirements. If this is the case, then Zeeko will notify customers at the time of ordering.

12.2 Compressed Air

The IRP machine operates with compressed air to fulfil the following functions:

1. Air purges to axes and joints exposed to polishing slurries
2. Linear encoder air purges
3. Bonnet (polishing tool) air pressure
4. Vacuum systems for vacuum workholding where fitted (chucks)
5. Pneumatic systems for the control of fluid systems

Minimum input pressure	6 bar
Maximum input pressure	8 bar
Volumetric requirement	215 l / min (air purges to max.)

Mist separators are fitted internally to all machines.

12.3 Environmental Specification

The IRP 400 must be installed inside a room with the following characteristics:

12.4 Temperature and Humidity

Operating Temperature: 15 – 35 deg C

IRP400 7Axis Fanuc – XY Linear

Product Specification

Max. Operating Humidity:	75% RH, non-condensing
Storage Temperature:	-15 – 50 deg C
Max. Storage Humidity:	80% non-condensing
Max. Temperature Gradient:	<2 deg C / hour
Recommended Temperature:	21 deg C \pm 0.5 deg C

12.5 Cleanliness

The IRP machines do not require siting in an ISO class cleanroom. However, we recommend that the machine is sited in a separate room to:

1. Rooms containing conventional milling and grinding machines
2. Rooms containing diamond turning machines
3. Rooms subject to metal swarf or grinding dust
4. Rooms subject to any other processes that generate airborne particulate matter

The room should be clean, but not necessarily a clean-room as classified by ISO. IRP machines typically use Cerium Oxide slurry as the polishing medium and when this dries on surfaces, it can produce a dust which would be classed as a contaminant in ISO-class cleanrooms. It is for this reason we recommend that if you require the rooms to be clean, you adhere to practices for cleanrooms of ISO class 8 or 9, but without the rigorous filtering required. The resulting air changes and also cleanliness protocols will ensure a room that is clean to a very high standard.

12.6 Room Vibration Requirements

Each IRP machine is equipped with passive vibration isolation feet. The IRP 600 is no different in this respect. In order to ensure best results, we recommend a vibration environment corresponding to:

Residential Day (ISO)

Contact

For more information, please visit our website (www.zeeko.co.uk) or contact us via the following:

Zeeko Ltd. | 4 Vulcan Court | Vulcan Way
Coalville | Leicestershire | LE67 3FW | UK
+44 1530 815 832
info@zeeko.co.uk
sales@zeeko.co.uk